



## CONTACT:

Technical/Musical Director - Derek Atherton

Email: [studio22recording@live.ca](mailto:studio22recording@live.ca)

(416) 226-4968

Official Website: [www.kathytaler.ca](http://www.kathytaler.ca)

## Instruments:

Lead Vox/Rhythm guitar

Lead Guitar/Vox

Electric Bass/Vox

Keys

Drums

## Input list

The following equipment is suggested and may be substituted by equipment of similar quality.

- Input List:
- Ch.1 kick – AKG D 112 or Beyer M88
  - Ch.2 snr top - Beyer 201 or sm 57
  - Ch.3 snr bot - Beyer 201 or sm 57
  - Ch.4 hat – AKG 451 or km 84
  - Ch.5 tom 1 - sennheiser e904
  - Ch.6 tom 2 - sennhieser e904
  - Ch.7 Floor - sennhieser e904
  - Ch.8 oh l – km84 or AKG 451
  - Ch.9 oh r - km84 or AKG 451
  - Ch.10 bass gtr - D.I.
  - Ch.11 bass gtr mic - M88 or Beta 58
  - Ch.12 elec gtr 1 – sm 57
  - Ch.13 elec gtr 2 – sm 57
  - Ch.14 keys l – d.i.
  - Ch.15 keys r – d.i.
  - Ch.16 Track L - d.i.
  - Ch.17 Track R - d.i
  - Ch.18 Lead Vox – Neumann KMS 105 or sm 58 (boom)
  - Ch.19 Lead Vox – H.H. Wireless sm 58 (straight)
  - Ch.20 B Vox 1 - sm 58 (boom)
  - Ch.21 B Vox 2 – sm 58 (boom)
  - Ch.22 vox spare mic (straight)
  - Ch.23 host mic /emcee - HH wireless sm 58
  - Ch.24 wild spotted leopard in pinstripe suit –wireless lavalier mic

**\* A snake with minimum of 2 mono returns is required for backing sequences that will be controlled from the stage**

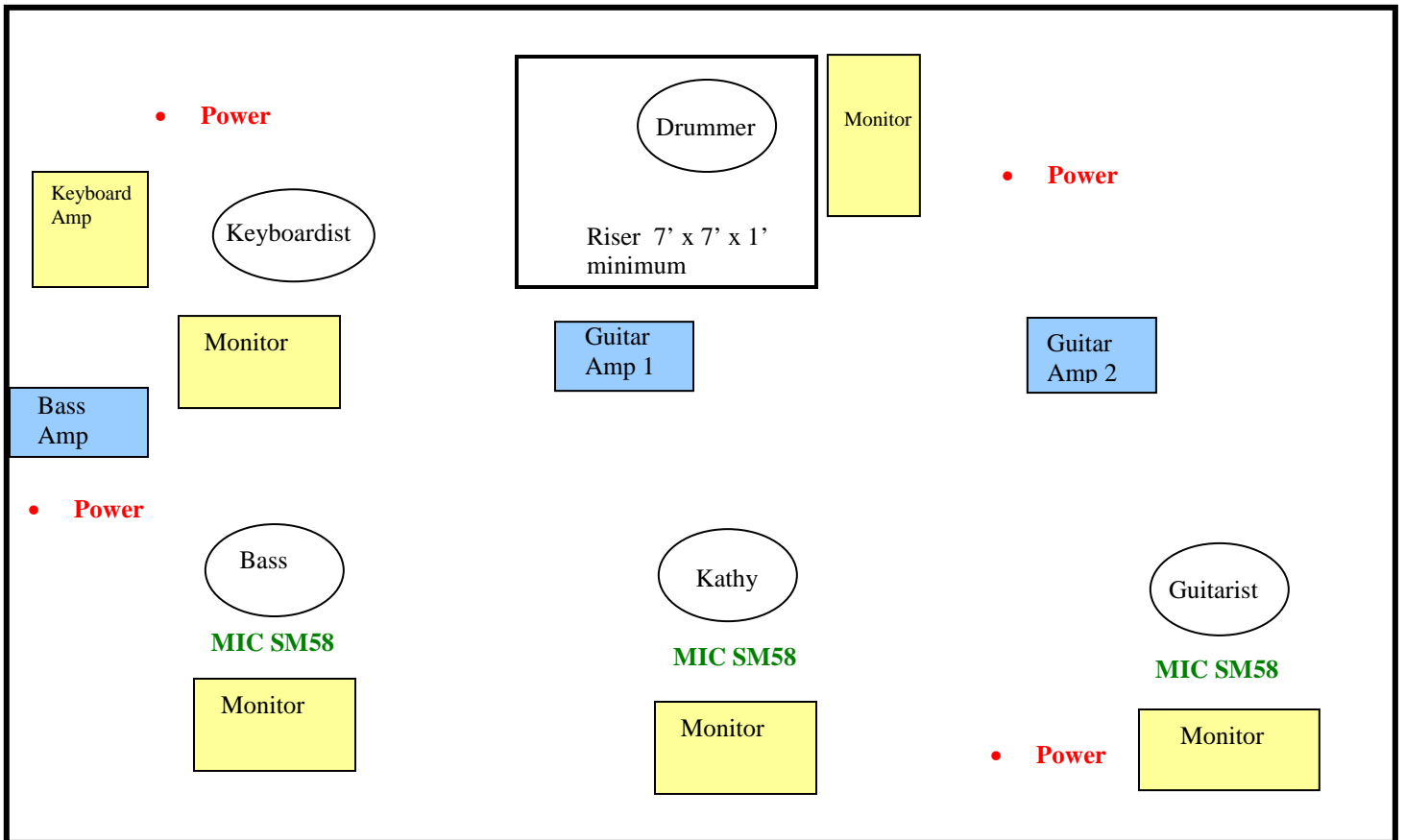

**Backline Requirements:**

**DW Drums** (or similar)

Bass Drum: 24"

(2) Snare Drums: 5"x14" Maple and 5" x 14" Vintage Brass

Toms: 2 rack toms, 1 floor tom

Cymbals: Zildjian 20" A Custom Projection Ride

Zildjian 19" A Custom Crash

Zildjian 18" A Custom Crash

Zildjian 17" A Custom Crash

Zildjian 17" K China

Zildjian 14" K Mastersound Hi Hats

DW Low Drum Throne

DW5002 Double Bass Drum Pedal

All necessary drum hardware

**Bass Amp** : Ampeg SVT or similar (minimum 4 x 15 inch speakers )

**Gtr 1**: Marshall JCM 2000 or similar with Footswitch

**Gtr 2**: Marshall JCM 2000 or similar with Footswitch

**Keyboard Amp**: Hartke KM200 or similar